

1 RISER PRECAST STEP UNIT

WIDTH "A"	APPROX. WEIGHT
36"	240 LBS
48"	355 LBS
60"	430 LBS
72"	475 LBS
96"	710 LBS

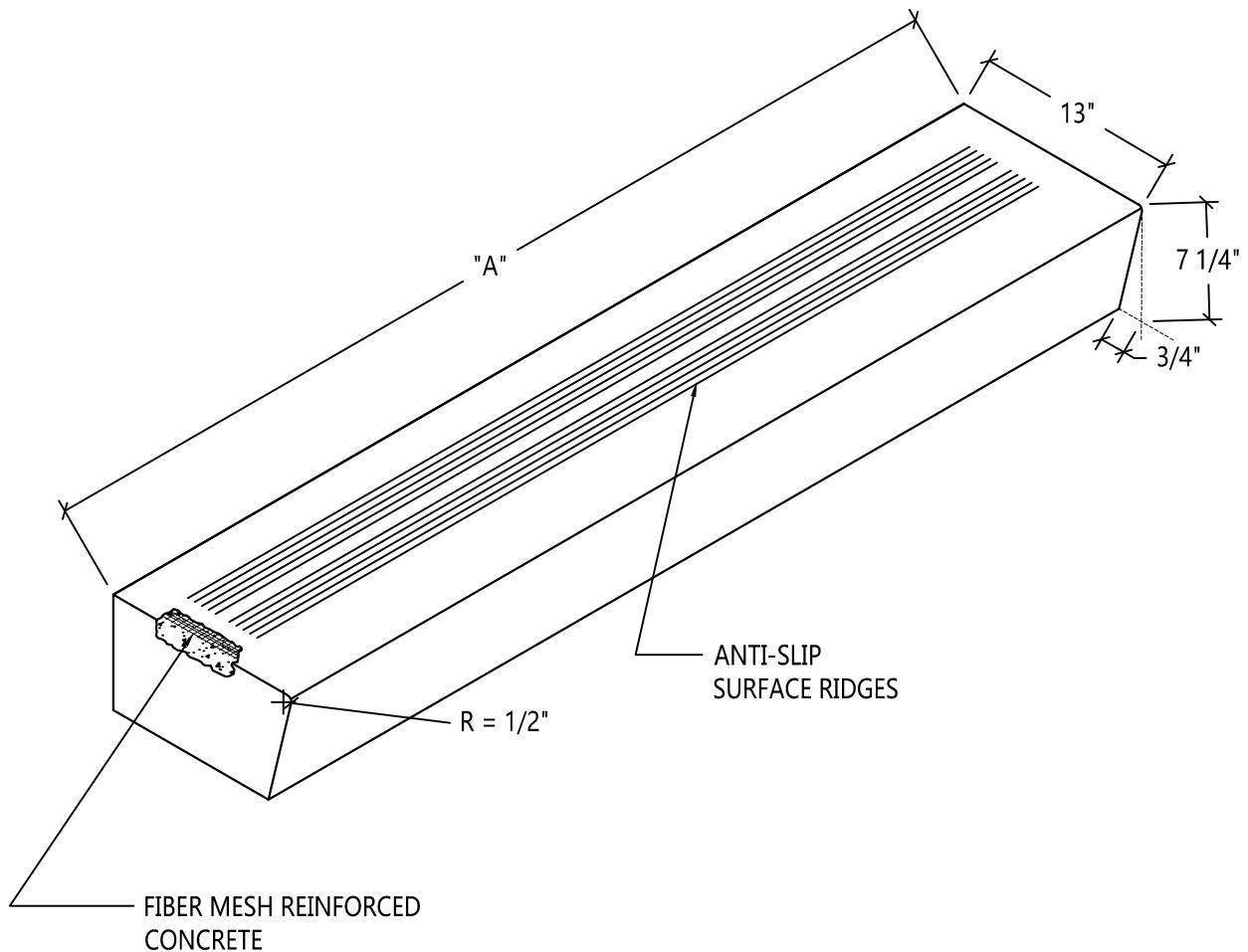

SPECIFICATIONS:

MINIMUM STRENGTH OF CONCRETE- 4,000 P.S.I. @ 28 DAYS

AIR ENTRAINMENT- 5 1/2% ± 1 1/2%

3/8" REBAR AROUND PERIMETER



Scranton Craftsmen, Inc



930 Dunmore Street

Throop, PA 18512

www.scrantoncraftsmen.com

sales@scrantoncraftsmen.com

Toll Free: 1800-775-1479

Phone: (570) 347-5125

Fax: (570) 489-4212