

# 2 RISER PRECAST STEP UNIT

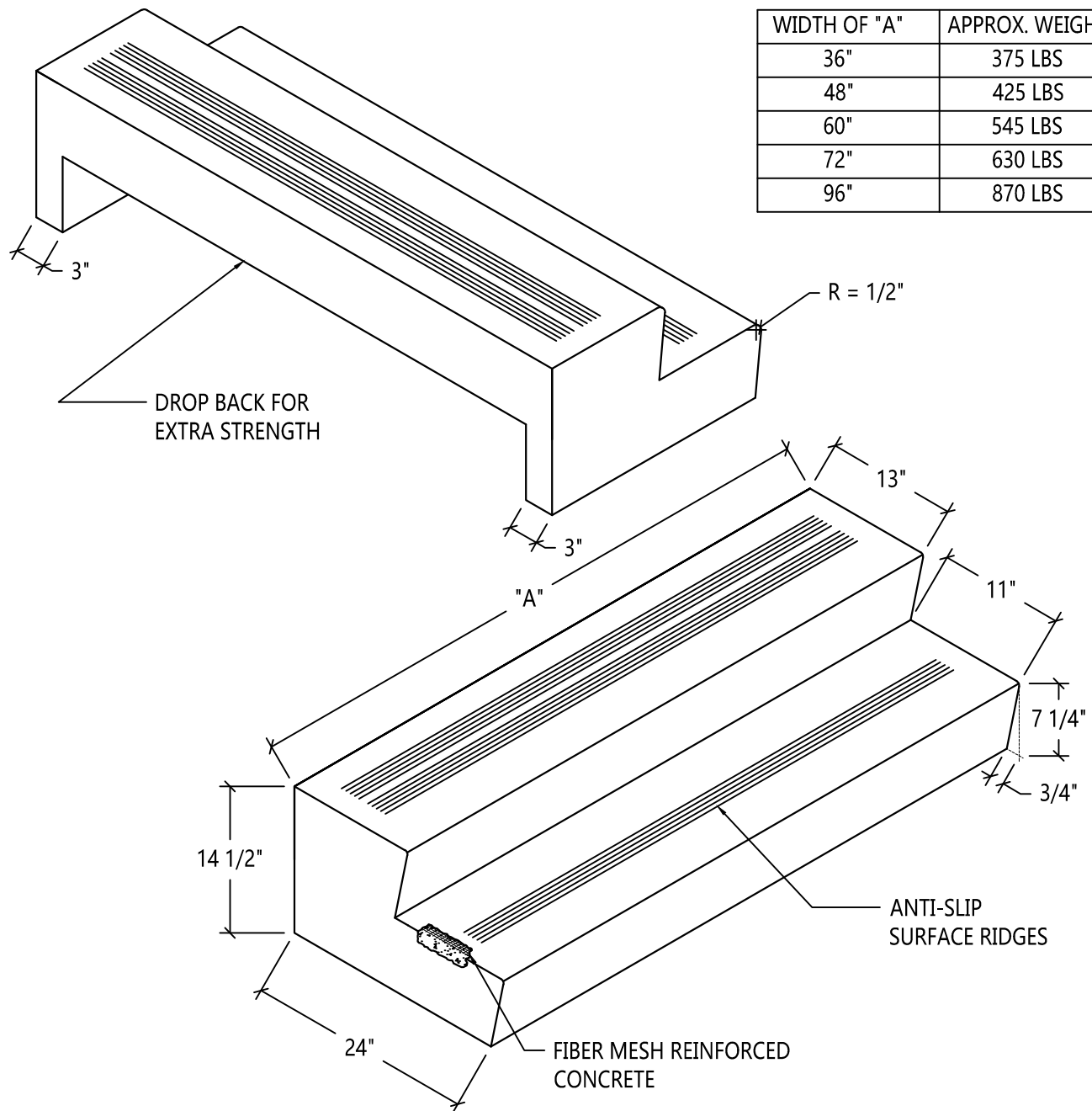

**SPECIFICATIONS:**  
 MINIMUM STRENGTH OF CONCRETE- 4,000 P.S.I. @ 28 DAYS  
 AIR ENTRAINMENT- 5 1/2% ± 1 1/2%  
 3/8" REBAR AROUND PERIMETER



## Scranton Craftsmen, Inc



930 Dunmore Street  
 Throop, PA 18512

[www.scrantoncraftsmen.com](http://www.scrantoncraftsmen.com)  
[sales@scrantoncraftsmen.com](mailto:sales@scrantoncraftsmen.com)

Toll Free: 1800-775-1479

Phone: (570) 347-5125

Fax: (570) 489-4212