

3 RISER PRECAST SIDE ENTRANCE STEP UNIT

DEPTH "A"	WIDTH "B"	LENGTH "C"	APPROX. WEIGHT
36"	36"	58"	1260 LBS
48"	48"	70"	1460 LBS
60"	48"	82"	1655 LBS

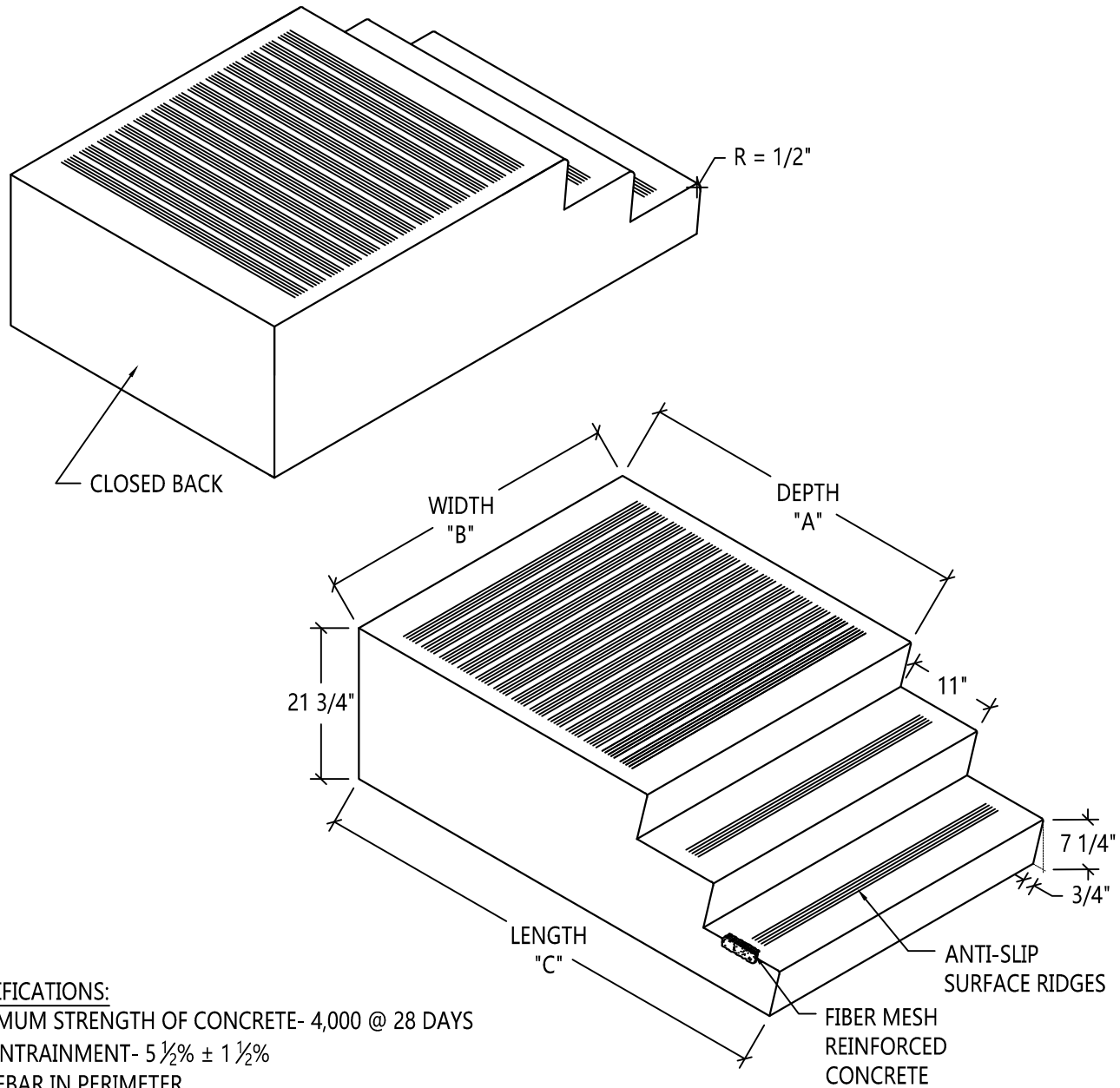

SPECIFICATIONS:
 MINIMUM STRENGTH OF CONCRETE- 4,000 @ 28 DAYS
 AIR ENTRAINMENT- 5 1/2% ± 1 1/2%
 3/8" REBAR IN PERIMETER



Scranton Craftsmen, Inc



930 Dunmore Street

Throop, PA 18512

www.scrantoncraftsmen.com

sales@scrantoncraftsmen.com

Toll Free: 1800-775-1479

Phone: (570) 347-5125

Fax: (570) 489-4212