

48" I.D. MANHOLE AND RISERS

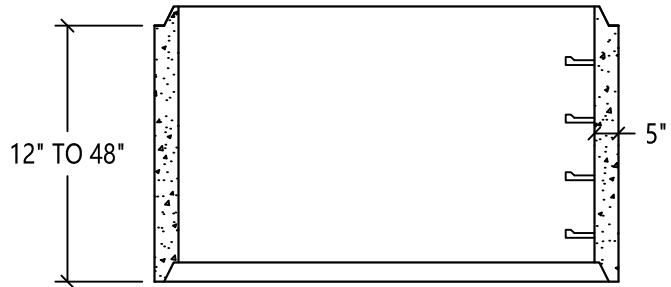

RISER SECTION

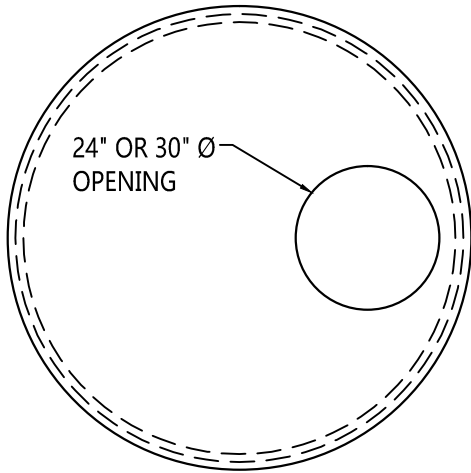
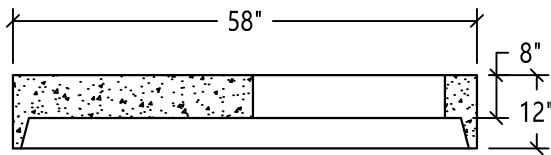

FLAT TOP SLAB

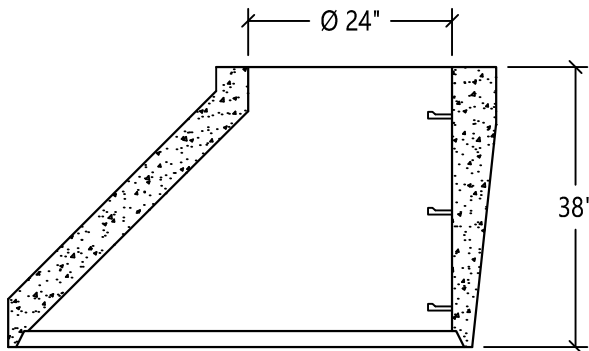

CONE SECTION

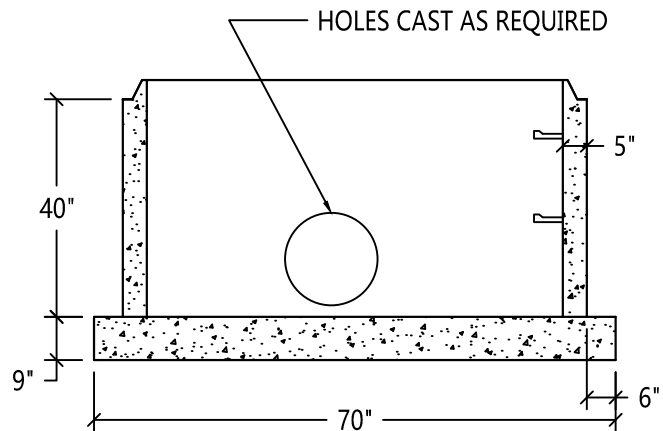

BASE SECTION

SPECIFICATIONS:

MINIMUM STRENGTH OF CONCRETE- 4,000 @ 28 DAYS

AIR ENTRAINMENT- 5 ½% ± 1 ½%

STEEL REINFORCEMENT- TO MEET PENN DOT RC39 SPECIFICATIONS



Scranton Craftsmen, Inc



930 Dunmore Street

Throop, PA 18512

www.scrantoncraftsmen.com

sales@scrantoncraftsmen.com

Toll Free: 1800-775-1479

Phone: (570) 347-5125

Fax: (570) 489-4212