

500 GAL. MONOLITHIC DOSING TANK

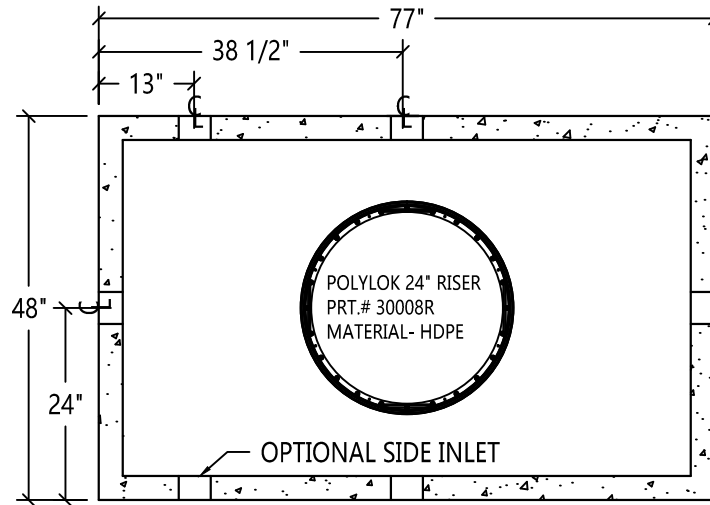

TOP VIEW

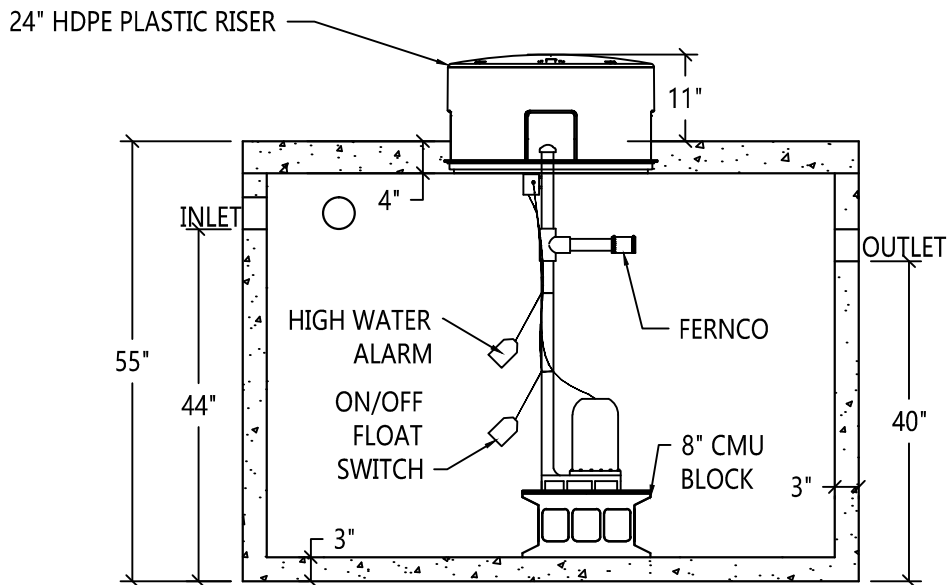

SIDE VIEW

SPECIFICATIONS:

MINIMUM STRENGTH OF CONCRETE- 4,000 @ 28 DAYS

AIR ENTRAINMENT- 5 1/2% ± 1 1/2%

STEEL REINFORCEMENT- 6" X 6" - 6 GAUGE WIRE MESH IN SIDES, BOTTOM & LID

JOINT- SEALED WITH SYNTHETIC RESIN OR EQUIVALENT

APPROXIMATE WEIGHT- 4,440 LBS.



Scranton Craftsmen, Inc



930 Dunmore Street

Throop, PA 18512

www.scrantoncraftsmen.com

sales@scrantoncraftsmen.com

Toll Free: 1800-775-1479

Phone: (570) 347-5125

Fax: (570) 489-4212