

# TYPE "D" PRECAST PERMENTRY

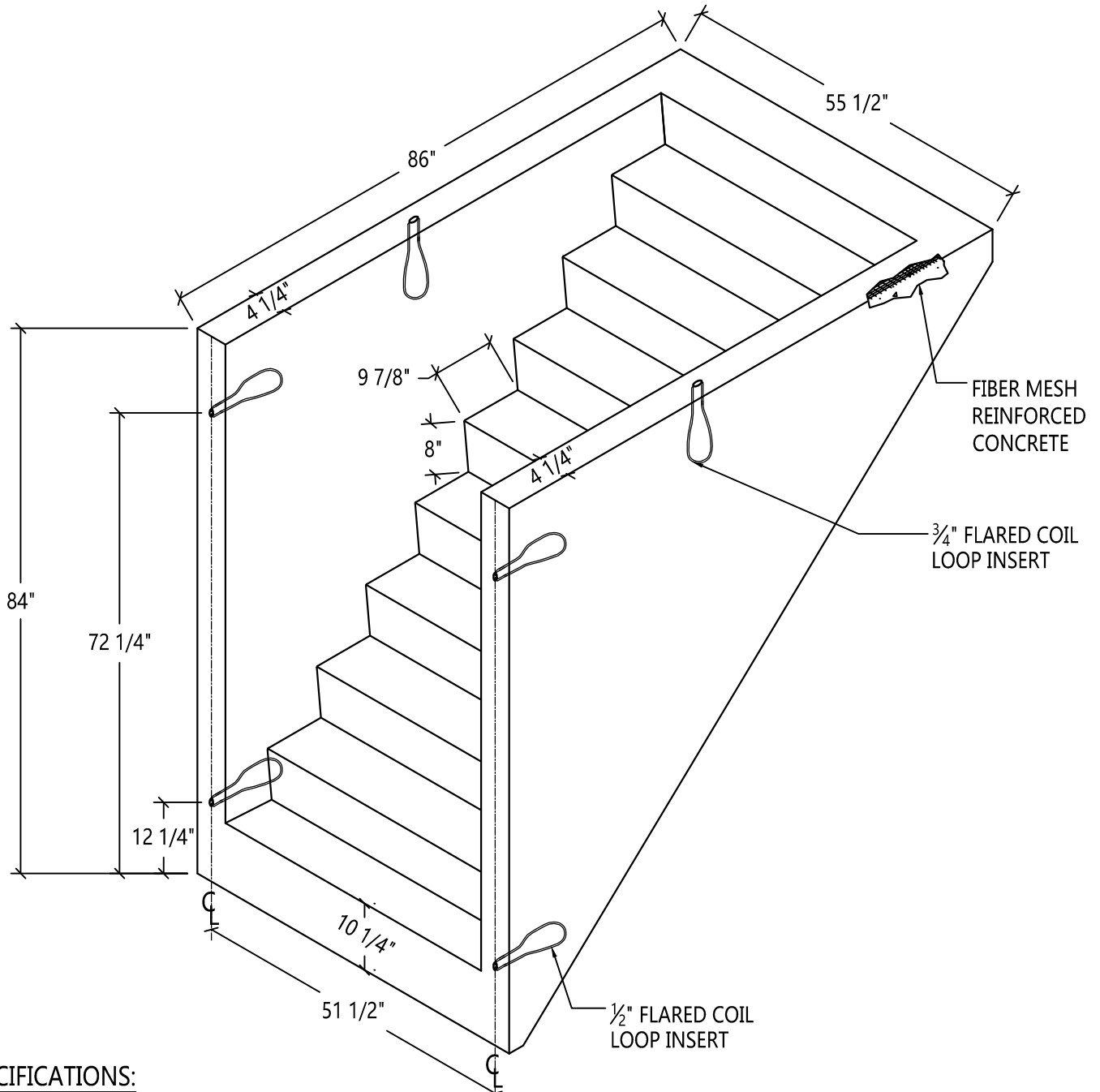

**SPECIFICATIONS:**

MINIMUM STRENGTH OF CONCRETE- 4,000 @ 28 DAYS

AIR ENTRAINMENT- 5 1/2% ± 1 1/2%

APPROX. WEIGHT- 5500 LBS



## Scranton Craftsmen, Inc



930 Dunmore Street

Throop, PA 18512

[www.scrantoncraftsmen.com](http://www.scrantoncraftsmen.com)

[sales@scrantoncraftsmen.com](mailto:sales@scrantoncraftsmen.com)

Toll Free: 1800-775-1479

Phone: (570) 347-5125

Fax: (570) 489-4212