

TYPE "S" PRECAST PERMENTRY

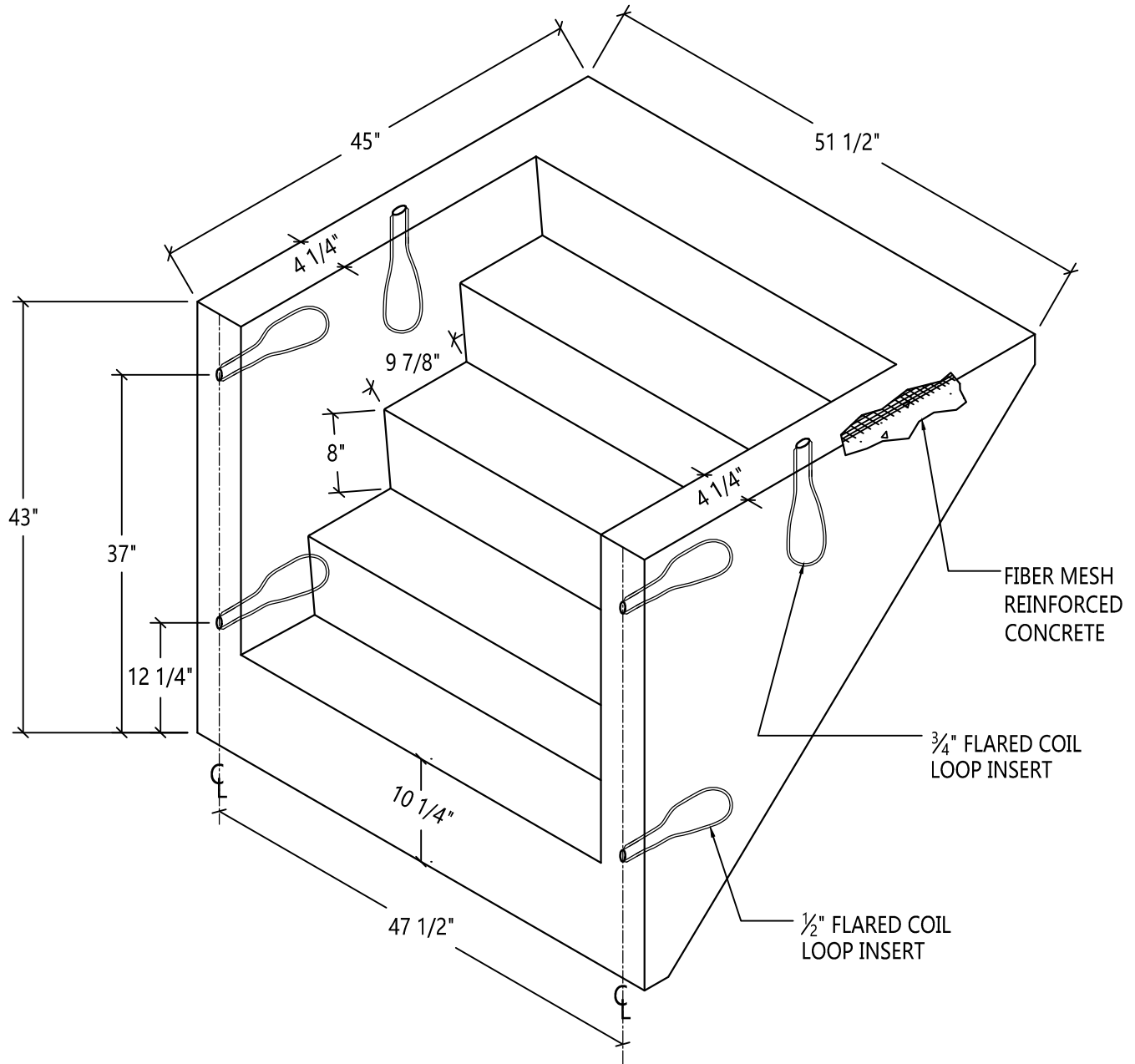

SPECIFICATIONS:

MINIMUM STRENGTH OF CONCRETE- 4,000 @ 28 DAYS

AIR ENTRAINMENT- 5 1/2% ± 1 1/2%

APPROX. WEIGHT- 1960 LBS



Scranton Craftsmen, Inc



930 Dunmore Street

Throop, PA 18512

www.scrantoncraftsmen.com

sales@scrantoncraftsmen.com

Toll Free: 1800-775-1479

Phone: (570) 347-5125

Fax: (570) 489-4212