

HALF CAP BLOCK

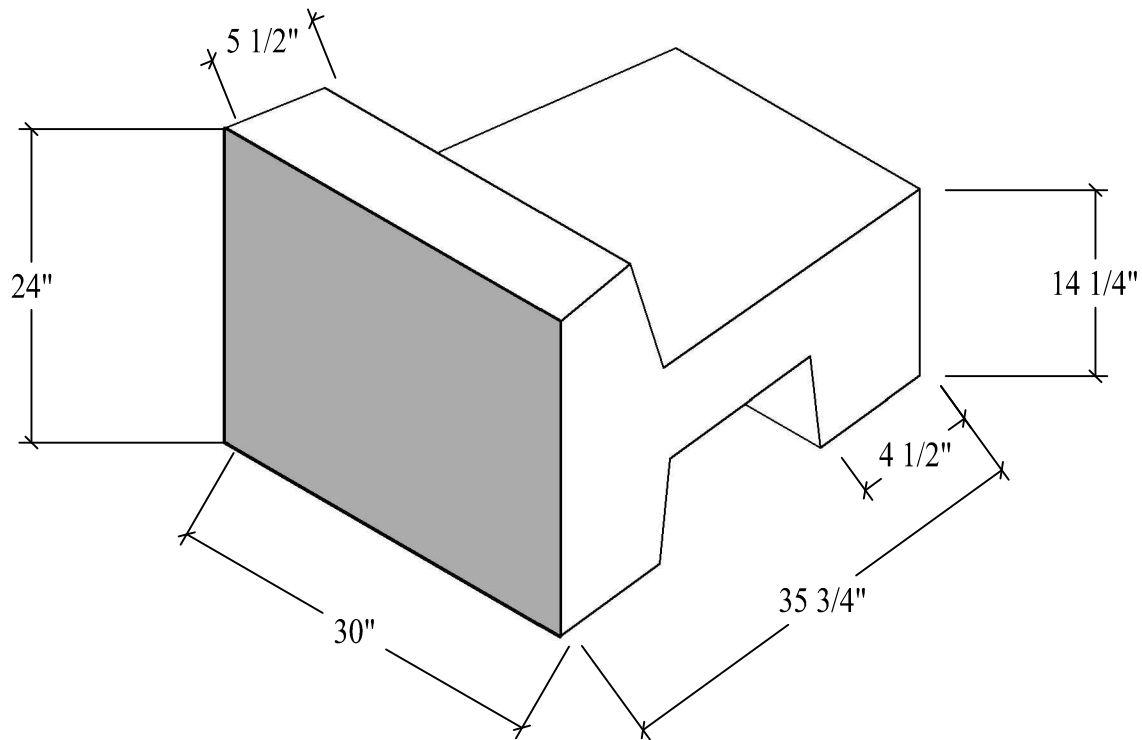

SPECIFICATIONS:

FIBERMESH REINFORCED CONCRETE- 4,000 PSI @ 28 DAYS

AIR ENTRAINMENT- $5\frac{1}{2}\% \pm 1\frac{1}{2}\%$

STEEL REINFORCEMENT- 4X4 - 4 GAUGE WIREMESH

APPROXIMATE WEIGHT: 1220 LBS.

SHADED AREAS REPRESENT FACE OF BLOCK



Scranton Craftsmen, Inc



930 Dunmore Street

Throop, PA 18512

www.scrantoncraftsmen.com

sales@scrantoncraftsmen.com

Toll Free: 1800-775-1479

Phone: (570) 347-5125

Fax: (570) 489-4212